

Metal case LiFePO4 battery pack

Model: BWP-FE12400-ATI-PF, 12.8V, 400Ah

Bestgo Battery Co., Ltd. is dedicated to providing advanced lithium ion batteries which feature both high power and energy densities with a long lifespans and ultra-safe performance. The cells are made using some unique manufacturing technologies developed over the years. These completely automated unique battery construction processes allow Bestgo to build higher quality lithium batteries which have superior performance characteristics over older manufacturing techniques. Using those unique technologies makes it possible to produce cells that have amazing consistency. Every step of the cells construction is tested with automated high precision quality control equipment. With these cells building the standard battery modules, Bestgo is in a very good position to help create solutions for a variety of energy storage systems applications.

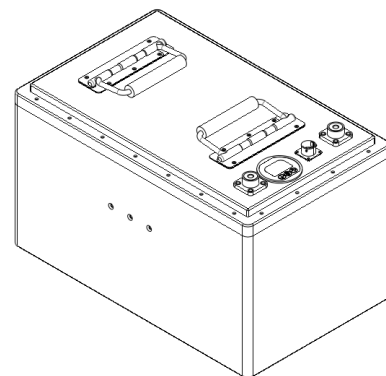

The specifications as shown in the chart below describes the performance and detailed technical requirements of the Li-ion batteries that are supplied by BESTGO BATTERY COMPANY LIMITED, the products mentioned in the specification in accordance with GB/T18333.1-2001 Standard.

Item	Rating	Note
Battery Model	BWP-FE12400-ATI-PF	-V1, V2, or -W1, -X1, means different versions
Battery pack Description	12.8V 400Ah lithium ion battery pack	Aluminum case, IP66, Indicator, with handles
Battery Chemistry	Lithium Iron Phosphate	LiFePO4
BMS and Fuse	PCB BMS and fuse are built inside case	The fuse is 250A slow type.
Battery pack Dimension (L*W*H) and connector type	432*266*254 ± 1 mm (metal case size) 17*10.5*10 inch's (metal case size)	Red and black terminals with M8 screw hole. Terminals have 18mm height above case.
Battery pack Weight	40.5 ± 0.5 kg	89 ± 1 lbs.
Rated Capacity	≥ 400 Ah @ C/3, 23°C/73°F	Measured as 2.5V cut off at cell level
Operating Voltage	12.8 V (average) @ C/3, 23°C/73°F	Working voltage range is 14.6 ~ 10.4 V
Charging Voltage	≤ 14.6 V @ CC/CV charge mode	Can be set to 14.4V for longer cycle life
Discharge cut off Voltage	10 ~ 10.4 V (When any cell volt reaches 2.5V may trigger this protection)	Set device (like a controller) low volt protection much higher to avoid trigger this protection.
Maximum Discharge Current	≤ 200 A @ 60min, 23°C, 30% ≤ SOC ≤ 100% ≤ 400 A @ 15s, 23°C, 30% ≤ SOC ≤ 100% ≤ 650 A @ 0.5s, 23°C, 30% ≤ SOC ≤ 100%	Please consider heat accumulation if long time discharging with a large continuous current.
Maximum Charge Current	≤ 200 A @ 60min, 23°C, 20% ≤ SOC ≤ 70% ≤ 400 A @ 15s, 23°C, 20% ≤ SOC ≤ 70%	Please consider heat accumulation if long time charging with a large continuous current.

Item	Rating	Note
Battery Cycle Life	≥ 3000 times @ 80% DOD, ± C/3, 23°C	After cycles can deliver ≥ 75% rated capacity
Internal Resistance	≤ 3 ± 2 mΩ	DCIR test method, @10s, 50% SOC
Temperature protection For charging process	0 ~ 5 °C ≤ sensor for cell ≤ 52 ~ 58 °C	If internal sensor detects a temperature that is outside of range, BMS will shut the pack off.
Temperature protection For discharging process	sensor for cell ≤ 65 ~ 70 °C	If internal sensor detects a temperature that is outside of range, BMS will shut the pack off.
Surrounded working condition temperature	Charge: 5 ~ 45°C Discharge: -20 ~ 55°C	Suggested for charging: 10 ~ 40°C Suggested for discharging: -10 ~ 45°C
Storage Temperature	-10°C ~ 40°C (for ≤ 3 months)	Keep SOC at 40~60% for long term storage

(60min means 60 minutes, 5min means 5 minutes, 15s means 15 seconds, 0.5s means 0.5 second.)

Inside the battery pack, the temperature sensors are attached to both the cells and the BMS. However, the temperature measurements are not very accurate. As a result, the BMS may trigger protections in a specific temperature range. When the battery packs undergo large continuous charging or discharging, please consider the heat accumulation in the battery pack, as it may trigger BMS protection if inside temperature became very hot. For more information, please contact us for the report of temperature raise with current passing test.

This model of battery packs belongs to Preferred series (PF series) that developed for universal applications. The battery chemistry is Lithium Iron Phosphate (LiFePO4), which is the safest chemistry among li-ion cells. Cells used in pack belongs to electric vehicle level cells (VDA cells), cells have passed the highest level of on road test in China, they have been massive used in high speed electric vehicles in China. Battery packs all have been equipped with aluminum cases for the best safety protection, they are light in weight, reliable in strength, with good heat transfer and a nice appearance.

Battery packs meet the IP66 enclosure requirements, so they can be used in many harsh conditions. The cells inside packs can provide superior performance but generate much less heat, along with passive-cooling design of cases, those allow us to build the packs without fan cooling. However, if batteries need to offer the continuous high-power input and output (such as charging from empty to full in 2 hours, or discharging from full to empty in 2 hours), and the surrounding temperature is high, please consider suitable air cooling or liquid cooling methods to keep the battery packs in a reasonable temperature range; this will allow the battery packs to work well and have a good battery life.

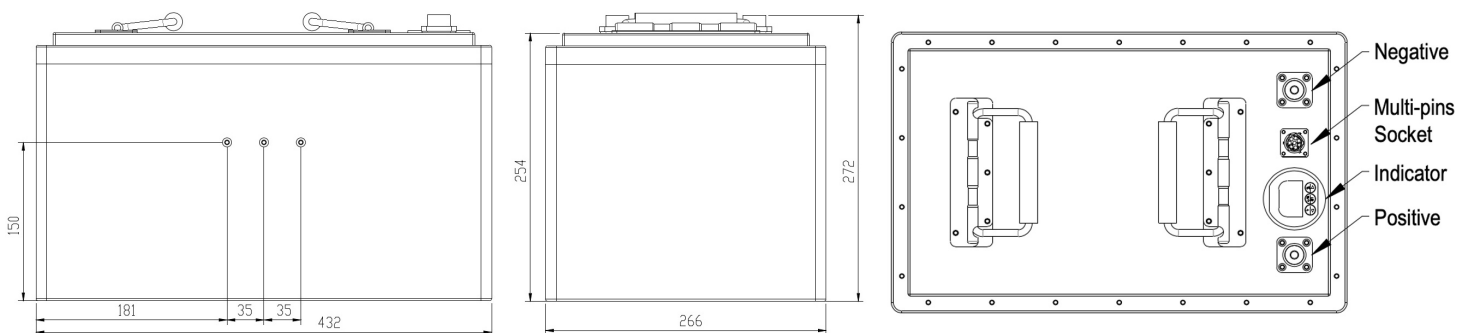

The battery pack has handle(s) for lifting and carrying, and an intelligent indicator to show the voltage, current, SOC, etc. There are also red and black terminals (which have **M8*18** screw holes) built on top for connection to a power cables. In addition, there are 3 bolt holes on each long side of battery pack, these screw holes are sized for bolts of M4*8, means battery packs can be fixed with such bolts. These bolt holes do not affect the IP66 rating, as the ends of the holes are completely sealed.

Operations on intelligent indicator

Firstly, press "A/Ah/set" button to light on indicator, then, If press "V/<" button, it will show Voltage.
 If press "%/>" button, it will show SOC percentage.
 If press "A/Ah/SET" button, it will show Current (Ampere), again press "A/Ah/SET" button, it will show Capacity (Ah).
 (Indicator can be manual calibrated, for more information, Please contact us for details.)

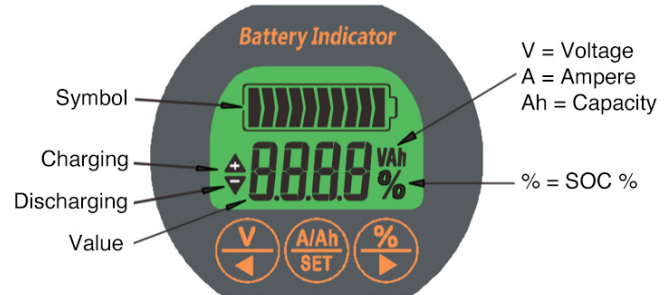

Multi-pins socket (nominal version and pro-version)

Here is a multi-pins socket built on the top of battery pack,

For the standard version of battery pack, socket is only used for connecting the second remote indicator, so customer can put this extra indicator any where as they wanted, to show the voltage, current, SOC or available capacity.

This second indicator is made of 3 parts, part A is an indicator, part B is a 2 meters extension wire, part C is a multi-pins connector. They can be connected to each other easily. By use more part B (extension wire part), can build the 2 meters, 4 meters or 6 meters long remote indicator..

For the pro-version battery pack, this socket can send out "on-off" signals to notify operator if battery pack is not in good range of temperature, voltage or current. The certain pins will have different on-off signals accordingly. Those pins can be used as switches to turn on the alert of lighter, speakers, or relays and contactors. They are not only used in single pack application, but also very necessary to be used in parallel configed battery systems. For more information, please review the document of pin defines of multi-pin socket.

The socket of pro-version battery pack have enough pins to connect the second remote indicator.

For OEM customize orders, this multi-pins socket can be customized to difference usages. For example it can be built with all inside cells have their cell volt wires and temperature sensor wires connected to this socket. then customer can use their own BMS connected to this socket to manage this battery pack. By this way, customer can build big battery system with dozens of such battery packs in parallel and series config, to reach the high voltage and big capacity capability. We can also increase the height of top lid, so it will have enough space for install customer's BMS inside battery pack (replace PCB BMS area), in this situation multi-pin socket can be used for signal transport and power supplying for inside BMS. We can offer such kind of pre-configured battery packs in mass volume, customer just need to open the lid and install their own BMS into battery pack.

Notes:

-V1, -W1, -X1, is 8-pins socket, standard version.

-V2, -W2, -X2, is 12-pins socket, standard version.

-V3, -W3, -X3, is 12-pins socket, pro-version version.

V, W, X means different production batch of cells, do not mix them if put in parallel configure usage.

Battery care and maintenance

- When the battery pack is over-discharged to the point that it triggers BMS protections, please stop using it immediately and recharge it as soon as possible (within 12 hours), even recharging 2~5% of the electricity back into the battery will contribute to the health of the battery. Do not over-discharge the battery, as this is very harmful to the cycle life of the battery and may cause permanent damage.
- Unlike with Lead Acid batteries, li-ion batteries do not require a full SOC for storage. Keeping the SOC in the middle range is good for long-term storage. For daily use, however, we suggest to charge to no more than 95% SOC and to discharge to no less than 10% SOC.
- For long-term storage please keep the batteries at 40%~60% SOC, discharge and recharge batteries 1~2 times after about 3~6 months in storage, as to maintain cycle health. Do not fully charge the batteries for the long-term storage, as that can be harmful to cycle life and performance.
- The battery pack can be discharged in lower temperatures, such as below 0°C, however the discharge performance and available capacity will be affected. Along with this, the battery pack can NOT be charged below 0°C, as that will cause permanent damage to Li-ion batteries and can even cause safety problems. For this reason, please only charge the packs above 0°C (32°F), recommended $\geq 5^{\circ}\text{C}$ ($\geq 40^{\circ}\text{F}$). The best working condition for the battery pack is 15°C~40°C (59°F~104°F). Take the necessary procedures to keep the batteries in a good temperature range.
- The Li-ion cell will be permanently damaged if the internal temperature gets too high (over 70°C, or 158°F). For this reason, do not continuously charge or discharge the battery pack with a high current if the surrounding temperature is really high, or else the battery cycle life and performance will be dramatically reduced.
- Do not wash the batteries with an organic solvent. In the event of a fire, DO NOT use a CO2 fire extinguisher, opt for CCl4, 6% F-500 fire suppressant mixed with 94% water, or sand soil instead.
- Please handle the pack with care to avoid severe vibrations or drops.
- Do not charge or discharge any battery pack without a BMS as this will allow the cells to be over-charged and under-discharged, leading to the serious damage to the batteries and risk of injury to the user.
- Do not over discharge the battery pack which may cause battery pack voltage lower than the "Discharge cut off Voltage" value, such kind of operation may easily damage the battery pack and **invalidate the warranty**.

Parallel config guideline (Optional, only for certain models)

If you have any doubts about parallel operation, please check with the supplier to see if the specified model supports parallel configuration or not. Most of those battery packs can be operated in parallel, please contact supplier for the guide file that is specific to that model and follow it exactly, the improper operation may damage the battery pack and invalidate the warranty.

The preferred series of battery packs should never be put in series configuration.

Battery pack electrical characteristics

Unless otherwise specified, this Li-ion battery pack charge and discharge parameters are:

Charging state:

When any single cell reaches 3.85 ± 0.05 V, BMS will trigger charge cut-off protection within 0.8~1.8 secs.

When the entire pack reaches a voltage of $3.65 * N$, taper the charging current until it is less than C/20, charging state is finished. The battery pack user can negotiate with the charger supplier to modify this C/20 to like C/25 or C/15 etc, it can increase or decrease the end charging time accordingly. It can also customize the $3.65 * N$ to $3.60 * N$, so the battery packs can obtain a longer cycle life.

(PS: N is the number of 3.2V parallel units in series config of battery pack)

Discharge state:

When any cell has a voltage less than 2.5V, the battery pack will trigger the low-voltage cut-off protection. Since there will be a severe dynamic voltage drop with a high-current draw when the cell is almost empty, it is difficult to have a cut-off voltage as high as 2.5V, as it will frequently trigger the protection if the application requires a high peak discharge current. Because of that high-current draw characteristic, We have set the PCB BMS to trigger the cut-off protection when any cell's dynamic voltage reaches 2.22~2.38 V for 0.3~0.7 of a second. Since this discharge cut-off protection is very low, the voltage protection setting for the controller should be set to a much higher value.

For example,

In a vehicle application, we typically set the low volt protection of the controller to " $3.0V * N$."

In some applications that need to offer a shorter high-current discharge at the end of SOC, such as a 2C discharge, the low volt protection of the controller can be set to " $2.8V * N$."

The important part is to set this value correctly, and to make sure there is still about 5%~10% of the electricity left in the battery pack after the device triggered protection. (The way to know how much electricity is left in battery pack is directly discharge the battery pack and record how much electricity been discharged.)

Single cell performance based on temperature and SOC

(For cells used in preferred series battery packs)

For the charging process, in a constant current state of CC/CV charge mode, **cell level**, (not for pack level)

$T \leq 0$ °C (32°F), it is not allowed to be charged.

0 °C $\leq T \leq 10$ °C (32°F $\leq T \leq 50$ °F), allow $\leq C/3$ charge current, suggest $\leq C/5$ charge current.

10 °C $\leq T \leq 15$ °C (50°F $\leq T \leq 59$ °F), allow $\leq C/2$ charge current, suggest $\leq C/3$ charge current.

15 °C $\leq T \leq 40$ °C (59°F $\leq T \leq 104$ °F), allow $\leq 1C$ charge current, suggest $\leq C/2$ charge current.

40 °C $\leq T \leq 50$ °C (104°F $\leq T \leq 122$ °F), allow $\leq C/3$ charge current, suggest $\leq C/5$ charge current. (Only for emergency use)

For the discharging process, with a pulse discharge current, **cell level**, (not for pack level)

-20 °C $\leq T \leq 0$ °C (-4°F $\leq T \leq 32$ °F), allow $\leq C/2$ pulse discharge current @ 30s, SOC $\geq 30\%$.

0 °C $\leq T \leq 10$ °C (32°F $\leq T \leq 50$ °F), allow $\leq 1C$ pulse discharge current @ 30s, SOC $\geq 30\%$.

10 °C $\leq T \leq 15$ °C (50°F $\leq T \leq 59$ °F), allow $\leq 1.5C$ pulse discharge current @ 30s, SOC $\geq 30\%$.

15 °C $\leq T \leq 40$ °C (59°F $\leq T \leq 104$ °F), allow $\leq 2C$ pulse discharge current @ 30s, SOC $\geq 30\%$.

40 °C $\leq T \leq 50$ °C (104°F $\leq T \leq 122$ °F), allow $\leq 1C$ pulse discharge current @ 30s, SOC $\geq 30\%$. (Only for emergency use)

The "T" is the temperature of the Li-ion cells, all of the above data is based an individual cell, so the entire battery pack performance should be reduced accordingly. When placing cells into a metal case to assemble a battery pack, be sure to consider the heat accumulation inside of the pack. When cells are in a discharging or charging state, they are sensitive to temperature, please keep them in the proper temperature ranges.

Requirements for the operation of li-ion battery packs (General purpose)

Before operating, please read the related documents to obtain a full understanding of the battery pack, charger, additional devices (such as a controller), and the necessary related components. Along with this, make sure they are all compatible with the battery pack and all of the necessary work has been done. The operator should have the clear understanding of the characteristics of Li-ion batteries and be professional in the installation and operation of the Li-ion battery packs. Please make sure the charger is suitable for the specified Li-ion battery type, do not use lead acid battery chargers for CC/CV mode which will offer pulse peak current in the last charging state, this is harmful to Li-ion batteries.

For some applications which need a constant high current for the entire discharging and/or charging state, in those high-current applications make to monitor the internal and external temperatures of the battery pack. If necessary, contact us for answers on a specific application or customize the battery pack parameters if need to.

Test Performance and Conditions (general)

For the battery packs which been sent to test labs or third parties for performance testing, the tests should be conducted on new batteries within three months after receiving the batteries. Batteries must not have been cycled more than five times before the tests. Unless otherwise defined, tests and measurements shall be done under a temperature of $23\pm 2^{\circ}\text{C}$ and relative humidity of 45~85%.

Item	Measuring Procedure	Required Results
Vibration test	After a standard charge, the battery / battery pack is to be tested as follows: Amplitude: 0.8mm Frequency: 10~55Hz(sweep:1Hz/min) Direction: X/Y/Z axis for 9~30min. The battery / battery pack is to be tested in three mutually perpendicular to each axis.	No fire, explosion, or smoke.
Short-Circuit Test	After a standard charge, the battery / battery pack is to be Short-circuited by connecting the positive and negative Terminals of the battery / battery pack with copper wire having a Maximum resistance load of 0.1 ohm.	No fire or explosion. The temperature of the exterior cell casing does not exceed 120°C .
Heating Test	The battery / battery pack is to be heated in a gravity convection or circulating air oven. The temperature of the oven is to be raised at a rate of $5\pm 2^{\circ}\text{C}/\text{min}$. At this temperature, the oven must be kept on for 10 minutes before the test can be concluded	No fire or explosion.
Over Charging Test	After a standard charge, the battery / battery pack is subjected to a charging current by connecting it to a DC-power supply. The beginning current is 3C, which is to be obtained by connecting a resistor of specified size and rating in series with the battery / battery pack. The test time is 2.5 hours. The initial current does not need to be maintained for the entire 2.5 hours.	No fire or explosion.

Transportation & Storage of li-ion Battery Pack (general)

Proper transportation and storage of Li-ion battery packs are critical, ensure this section is followed carefully to prevent damage to the pack and injury to the user:

- Can be transported via truck, train, and ship, kept them out of the sun and rain during transportation.
- Handle the battery pack and cells with care when assembling and disassembling, do not drop or excessively shake them.
- Do not place any heavy objects on the battery pack during transportation.
- Do not transport the batteries with flammable material, explosives, or sharp objects.
- Follow all local laws and regulations for transporting Li-ion batteries. Ensure the packaging is marked with waterproof stickers clearly labeling the product held within.

After-sale Service

For both warranty and after-sale service, the following will be enforced:

Warranty year(s) for this model of battery pack are specified by supplier. During the warranty period, we will take responsibility for the replacement or repair for any of the following issues:

- The whole battery pack cannot be charged or discharged.
- Under the standard testing condition, the capacity is less than 80% in the end of the first year, or 70% in the end of last warranty year (if the last warranty year is provided in the warranty period).
- There is liquid leakage.
- There is some damage on battery pack's case and accessories that are caused by the battery.
- The charger is not working properly.

However, we will not take responsibility in the following situations:

- Expired warranty period.
- Battery damage as a result of improper handling.
- The battery pack is dismantled and converted.
- There is visible damage to the BMS that was not caused by battery failure.
- Damage caused by using an incorrect charger for the pack.

Revision Date: 12th April, 2021
PF series Datasheet
BFDS20210412 D30