

Preferred series li-ion battery packs

Model: 48V, 24V, 12V, 100 ~ 400Ah series

Bestgo Battery Co., Ltd. is dedicated to providing advanced lithium ion batteries which feature both high power and energy densities with a long lifespans and ultra-safe performance. The cells are made using some unique manufacturing technologies developed over the years. These completely automated unique battery construction processes allow Bestgo to build higher quality lithium batteries which have superior performance characteristics over older manufacturing techniques. Using those unique technologies makes it possible to produce cells that have amazing consistency. Every step of the cells construction is tested with automated high precision quality control equipment. With these cells building the standard battery modules, Bestgo is in a very good position to help create solutions for a variety of energy storage systems applications.

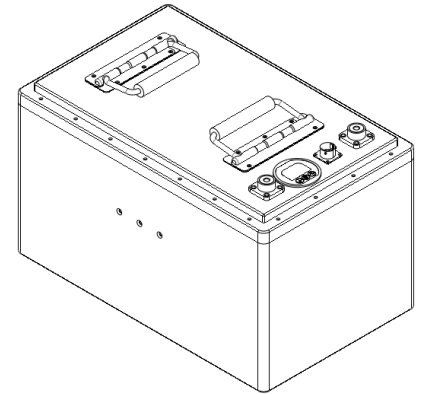

Battery model	Volt	Capacity	Case Size (L*W*H)	Weight	Max discharge short / peak	Max charge short / peak
BWP-FE12200-ATI-PF	12.8 V	200 Ah	310*266*229 ± 1 mm	22.3 ± 0.2 kg	200 A / 400 A	100 A / 200 A
BWP-FE12400-ATI-PF	12.8 V	400 Ah	432*266*254 ± 1 mm	40.5 ± 0.5 kg	200 A / 400 A	200 A / 400 A
BWP-FE25100-ATI-PF	25.6 V	100 Ah	310*266*229 ± 1 mm	22.3 ± 0.2 kg	120 A / 260 A	50 A / 100 A
BWP-FE25200-ATI-PF	25.6 V	200 Ah	432*266*254 ± 1 mm	40.5 ± 0.5 kg	200 A / 400 A	100 A / 200 A
BWP-FE51100-ATI-PF	51.2 V	100 Ah	432*266*254 ± 1 mm	40.5 ± 0.5 kg	120 A / 260 A	50 A / 100 A

Bestgo Battery Co., Ltd. developed the "Preferred series" li-ion battery packs to suit many different applications. They are built using LiFePO4 battery chemistry which is the safest chemistry among li-ion cells. The Preferred packs are made with aluminum cases making them light in weight, reliable in strength, with good thermal transfer characteristics to assure a better safety and performance. Those LiFePO4 cells also have ceramic insulation between the copper and aluminum plates which is another improvement in safety assurance. Battery packs have a nice appearance with rounded corners and stainless-steel handle(s) for carrying.

These Preferred battery packs meet IP66 levels so they can be used in many harsh conditions. They have the BMS and fuse built inside. In addition, they feature an intelligent indicator to show the voltage, current, and the packs State Of Charge, 'SOC'. There are red and black terminals with M8 screw holes built on top for power cable connection. These Bestgo Preferred packs are flexible in configuration and can be parallel configured (not in series) for larger energy storage applications.

Revision Date: 9th Feb, 2021

PF series Datasheet

BFDS20210209 D29